

1 Introduction

Thank you for purchasing a KERN WTB scale. These scales are rugged, simple to operate, and can be used without connection to an external power supply. The scale has a menu system which allows it to be adapted to your needs.

Please read through these Operating Instructions carefully, and always follow them!

1.1 Safety and the environment

English



- **Read through** these Operating Instructions carefully, even if you already have experience of KERN scales. Only ever use your scale as described in the Operating Instructions. Be sure to follow the instructions for putting your new scale into operation.
- **Do not** use the scale in a wet or explosive environment.
- For **connection to the power supply** use only the AC adapter delivered with the scale. Before you connect the scale to the power supply check that the voltage stated on the AC adapter is the same as the local power supply voltage. If it is not, **do not connect the AC adapter under any circumstances** but contact your dealer.
- Although your scale is very ruggedly constructed, it is nevertheless a precision instrument. Impacts to the weighing pan, or placing excessively heavy loads on it, can damage the scale.
- **Observe** local and national environmental regulations when disposing of the scale. The scale is fitted with a storage battery that contains heavy metals. **Do not** dispose of the battery as normal waste! Observe local regulations for disposal of environmentally harmful substances.



1.2 Selecting a location

Selecting a suitable location makes a decisive contribution to precise measurement results and lengthens the service life of the scale:

- Choose a stable, vibration-free surface which is as horizontal as possible.
- Ensure there are no excessive fluctuations in temperature, and no direct sunlight.
- Make sure that the environmental conditions are met (Chapter 9.1).
- Avoid drafts (e.g. from fans or air conditioning).
- After any major change of geographical position, the scale should be newly adjusted (calibrated) (Chapter 4.3).

2 Putting the scale into operation

2.1 Remove the transport arrestment

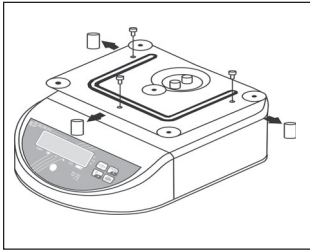

- Remove the 3 screws of the transport arrestment in the weighing-pan support and the 3 plastic inserts between the weighing-pan support and the scale housing.
- Place the weighing pan on the scale.

2.2 Leveling the scale

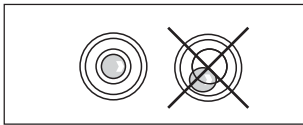

- Level the scale horizontally by turning the leveling screws. The air bubble of the level indicator must lie within the black inner circle.

2.3 Power supply

The scale is normally powered by the built-in storage battery. The AC adapter is only used for charging the storage battery. While the battery is being charged, the scale receives power from the power supply network, so you can still work with the scale even if the battery needs recharging. Battery charging also continues while the scale is switched off. The time required for recharging depends on how low the charge in the battery has become. However, to avoid overcharging the battery, do not leave the scale connected to the power supply with the AC adapter for more than 24 hours.

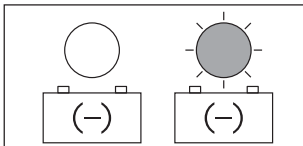

Battery operation (AC adapter not connected)

Observe the red LED above the battery symbol :

LED is not lit: The battery is sufficiently charged.

LED flashes: The charge of the battery is almost exhausted. Connect the AC adapter as soon as possible to recharge the battery.

Charging the battery/operating from the power supply

The connecting socket for the AC adapter is located underneath the balance adjacent to the front-left leveling screw. Remove the rubber plug and connect the AC adapter to the scale and to the power supply.

Observe the red LED above the battery symbol :

LED flashes: The scale is receiving power from the power supply network, the battery is being charged.

LED is continuously lit: The battery is fully charged, the AC adapter can be disconnected again.

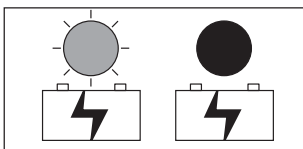

3 Daily operation

3.1 Switching the scale on and off



To switch the scale on: Check that there is nothing on the weighing pan. Press the **ON/OFF** key until the display appears. After the scale has been switched on, it performs a self-test in which all the segments and then various items of information about the scale are briefly displayed. When the weight display appears, the scale is ready to weigh and is automatically set to zero (the LED above the **→0←** symbol is lit).



To switch the scale off: Press the **ON/OFF** key and hold it down until "OFF" appears in the display. The display then goes out, and the scale is switched off.

English

Energy-saving function and automatic switchoff

For **battery operation** the scale has an energy-saving function and an automatic switchoff function which can be both activated and deactivated in the menu (Chapter 4).

If the **energy-saving function is** activated (factory setting), when the scale is powered from the battery it automatically switches into "Standby" mode after two minutes if no weight change takes place and no key is pressed. The display is filled with decimal points instead of digits. As soon as a weight is placed on the pan or a key is pressed, the scale returns to normal weighing mode.



If the **automatic switchoff function is** activated (it is deactivated at the factory), the scale switches off automatically after 15 minutes in "Standby" mode.

3.2 Simple weighing



- Set the scale to zero with the **→0←** key. The LED above the **→0←** symbol lights as confirmation.

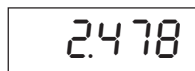

- Place the item to be weighed on the pan. The LED above the **→0←** symbol goes off.
- Read off the weighing result. The LED to the right of the weighing result shows the current weighing unit (the unit can be changed in the menu, see Chapter 4).

3.3 Weighing with tare



- Place the empty weighing container or packaging component on the weighing pan and press the **TARE** key to tare the scale. The zero display appears and the LED above the **NET** (net weight) symbol is lit.

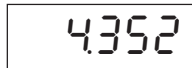

- Place the item to be weighed on the scale and read the result (net weight of the item being weighed).

The saved tare weight is retained until you either define a new tare, or press the **TARE** key when the weighing pan is empty, or switch off the scale.

3.4 Weighing with limit values

You can define an upper and a lower limit value and thereby ensure that the amount of substance weighed is always exactly within the defined tolerances.

Note: Limit-value monitoring is switched off at the factory and must be activated in the menu if required (Chapter 4.2, menu item S3). You can also specify in the menu whether the balance should warn of violations of limit values.

English



Defining limit values

- Press the **F** key. The current upper limit value is displayed (the LED above the **+** symbol is lit). If you want to set an upper limit value, continue with the next step. If you want to set a lower limit value, press the **ON/OFF** key and the LED above the **—** symbol will be lit. Every time the **ON/OFF** key is pressed, the scale changes between the upper and the lower limit value.

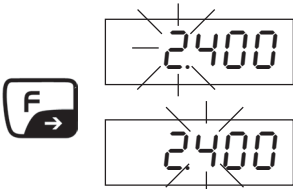

- The first digit of the selected limit value flashes and can now be changed. If you do not want to change the first digit, press the **F** key and the second digit will start to flash. Each time the **F** key is pressed, the display moves to the next digit. After the last digit the display returns to the first digit.

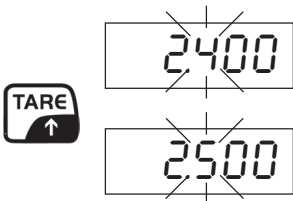

























- To change the selected (flashing) digit, press the **TARE** key repeatedly until the desired number is displayed. Then press the **F** key to move to the next digit and change this digit.

- To complete the input, press the **→0←** key. The scale stores the limit value and returns to weighing mode.

Weighing with limit values

Weighing in Weighing Mode is made easier for you by the two LEDs above the **UNDER** and **OVER** symbols as well as a beep. The behavior of the two LEDs and the beep depend on the respective setting in the menu (Chapter 4.2, menu item S3). The table below shows how the two LEDs and the beep behave for various settings in menu item S3.

S3 =	No load on balance	Load < lower limit value	Load between limit values	Load > upper limit value
1				
2				
3				
4				
5				
6				

4 The menu

The menu can be used to change the settings of the scale and activate functions. The menu consists of two parts, the **user menu** and **service mode** (see overview in Chapter 4.2).

The **user menu** contains frequently used settings and functions and is easy to call up.

Service mode provides the same possibilities as the user menu as well as additional functions for the service technician. To call up service mode a tool is required.

4.1 Operating the menu



Calling up the user menu

With the scale switched off, press the **→0←** key and hold it down. Switch on the scale with the **ON/OFF** key.

"Setup" appears briefly in the display and then the first menu block of the user menu ("S1") appears.

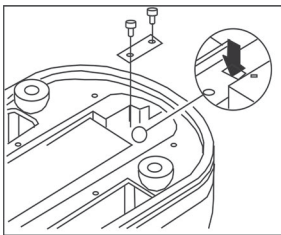

Calling up service mode

Remark: If the scale is verified, the official seal has to be destroyed. Once this seal has been destroyed, the scale must be reverified by an accredited organization, and a new official seal must be affixed before the instrument may be used as a verified scale again!

With the scale switched on, remove the cover of the storage battery underneath the scale (6 screws). Remove the calibration plate (2 screws). To remove the calibration plate, the sticker has to be destroyed which covers one of the two screws.

Use a small flat-tip screwdriver to short-circuit the two contacts in the rectangular opening (see arrow).

"Setup" appears briefly in the display and then the first menu block of service mode ("CTY") appears.

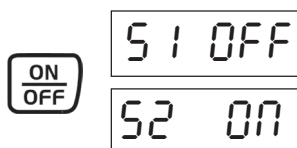

Selecting the menu block

Press the **ON/OFF** key to confirm the setting in the current menu block and then select the next menu block.

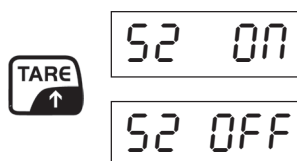

Changing the setting

After you have selected the desired menu block, you can use the **TARE** key to switch between the available settings. The number of available settings differs according to the menu block.

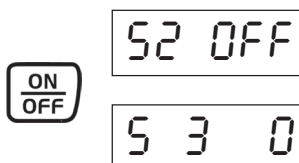

Confirming the setting

When the desired setting has been made (or if there is no need to change the current setting), it must be confirmed by pressing the **ON/OFF** key. The next menu block then appears automatically in the display.

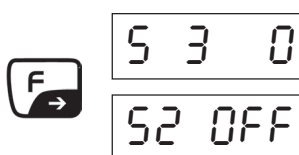

Navigating backwards in the menu

If you wish to navigate backwards in the menu, i.e. display the previous menu block again, you can do so at any time with the **F** key. This way you can check the settings you made and change them again if necessary.

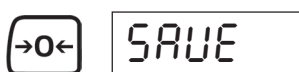

Quitting the menu

When you have made all the desired settings, press the **→0←** key. You will be asked whether you wish to save the settings ("SAVE"). Note: This question also appears after the last menu block.

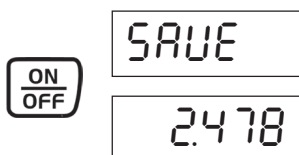

Saving the settings

If you want to save the settings, press the **ON/OFF** key. When the save has been done, the scale automatically returns to weighing mode.

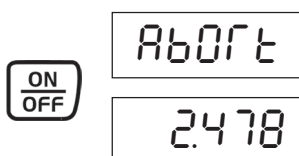

Rejecting the settings

If you do not want to save your changes, press the **TARE** key. The display shows "Abort". Press the **ON/OFF** key and the scale returns to weighing mode without the changed settings being saved.

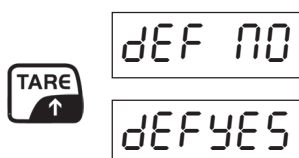

Restoring the factory settings

The factory settings can only be restored in **service mode** in the menu block "DEF" ("Default"). If you want to restore the factory settings, select "DEF YES" and confirm with the **ON/OFF** key. Then press the **→0←** key and confirm the "SAVE" prompt with the **ON/OFF** key. **Note: When the factory settings are restored, all individual settings are lost!**

4.2 Menu overview (user menu and service mode)

Menu block	Settings	Explanation
CTY		Selects the region (determines which weighing units are available under "S5")
	EU GE	Europe USA
DEF		Restores the factory settings
	No Yes	Do not restore the factory settings Restore the factory settings (happens immediately after confirmation!)
S1		Automatic switchoff function (see description in Chapter 3.1)
	Off On	Deactivates the automatic switchoff function Activates the automatic switchoff function
S2		Energy-saving mode (see description in Chapter 3.1)
	On Off	Activates the energy-saving mode Deactivates the energy-saving mode
S3		Limit-value monitoring (see description in Chapter 3.4)
	0	No limit-value monitoring (F key and alarm via beep and LEDs deactivated)
	1	
	2	
	3	
	4	
	5	
6		
	Limit-value monitoring activated, behavior of LEDs and beep (see description in Chapter 3.4).	

Menu block	Settings	Explanation
S4		Adaptation to the environmental conditions (filter)
	0	Very stable environmental conditions, weak filtering of the weighing signal
	1	Normal environmental conditions, average filtering of the weighing signal
	2	Unstable environmental conditions, stronger filtering of the weighing signal
	3	Very unstable environmental conditions, very strong filtering of the weighing signal
	4	As for setting 0, but with slower updating of the display value
	5	As for setting 1, but with slower updating of the display value
	6	As for setting 2, but with slower updating of the display value
	7	As for setting 3, but with slower updating of the display value.
S5		Weighing unit
	g	Gram
	kg	Kilogram (only available if the region is set to "EU" (Europe), see menu block "CTY")
	lb	Pound (only available if the region is set to "GE" (USA), see menu block "CTY")
	oz	Ounce (only available if the region is set to "GE" (USA), see menu block "CTY")
S6		Brightness of the display
	0	Very bright
	1	Bright
	2	Dark
	3	Very dark
DSP (S7)		Type of display
	On	Weight value is only displayed when stable
	Off	Weight value is displayed continuously, irrespective of whether it is stable
S8		Resolution of the scale (only available in the user menu when "S9" = "On")
	Off	3000d
	On	6000d/7500d (depending on the capacity of the scale)
S9		Access to menu item S8 from the user menu
	Off	Menu item S8 is not available in the user menu (S8 is only accessible in service mode)
	On	Menu item S8 is available in the user menu
S10		Extended display
	Off	Normal weight display depending on the resolution of the balance (see menu item S8)
	On	Only for tests: Display in d (max. scale capacity = 30,000d), keys →0← and →T← disabled
S11		Display of negative weight values
	On	Display of negative weight values disabled (display shows "uuuuuu"), taring not possible
	Off	Display of negative weight values enabled, taring possible (not allowed for certified balances)
S12		Speed of display when removing the load
	On	Return to zero by display is fast
	Off	Display returns to zero at normal speed
BAT		Type of internal power supply
	CH	Rechargeable storage battery
	D	Commercial battery size "D" (IEC "R20")
GEO		Geo adjustment value (adaptation to local gravitational conditions, see table in Chapter 5)
	0 ... 31	Factory setting according to region
CAL		Scale adjustment (calibration)
	No	Do not perform adjustment
	Yes	Perform adjustment (see description in Chapter 4.3)

Except where the factory settings are shown **bold**, the factory setting depends on the country in which the balance was purchased, on the model of the balance, or on the respective weights and measures law.

Only the menu blocks shown above with a gray background are available in the user menu; the other menu blocks are only accessible in service mode.

4.3 Adjusting (calibrating) the scale

The scale was adjusted at the factory. However, we still recommend adjusting the scale when it is put into operation for the first time, and thereafter at regular intervals, especially after a change of location.

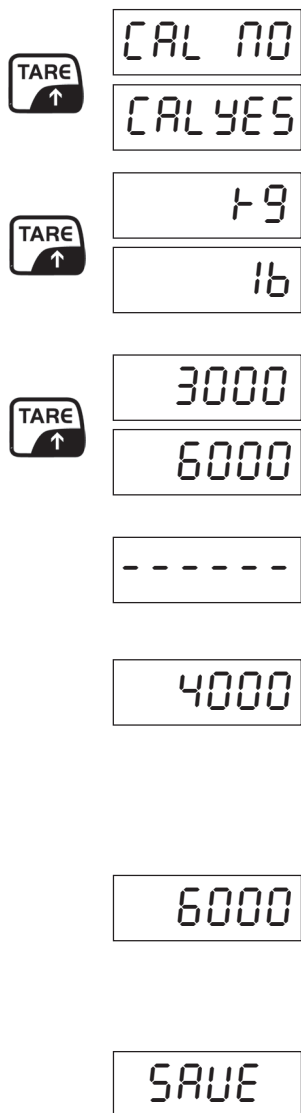
- 
- Adjustment can only be done in **service mode (see chap. 4.1)**. Before doing the adjustment, the geo adjustment value must be checked for correctness in the "GEO" menu block (see table in Chapter 7).
- In service mode call up the "CAL" menu block. With the **TARE** key select "CAL YES" and then start the adjustment with the **ON/OFF** key.
 - Select the desired **weight unit for the adjustment** and confirm with the **ON/OFF** key. The units available depend on the selected region (menu block "CTY"): for the setting "EU" (Europe) only "kg" is available while for the setting "GE" (USA) there is a choice between "kg" and "lb".
 - Select the **maximum capacity of the scale** (this is printed below the display, adjacent to the level indicator) and confirm it with the **ON/OFF** key. **Note:** The values in the display have a 1000x higher resolution, i.e. a displayed value of 6000 represents 6 kg or 6 lb (depending on the unit selected previously) and a displayed value of 15000 represents 15 kg or 15 lb.
 - The scale prompts you to **empty the weighing pan**. Remove any loads on the pan and confirm this with the **ON/OFF** key. The scale then performs a **zero setting** during which a counter is displayed which counts backwards from 5 to 1.
 - After the zero setting, you are prompted to place an **adjustment weight** on the pan which corresponds to **2/3 of the selected capacity** (in this example 4 kg/lb, corresponding to 2/3 of the weighing capacity of 6 kg/lb). Confirm that the weight has been placed on the pan with the **ON/OFF** key. While the weight is being measured, a counter is again displayed which counts backwards from 5 to 1.
 - The scale now prompts you to load the weighing pan with the adjustment weight which **corresponds to the selected capacity** (in this example 6 kg/lb). Confirm that you have placed the weight on the pan by pressing the **ON/OFF** key. While the weight is being measured, a counter is again displayed which counts backwards from 5 to 1.
 - **The adjustment is complete.** Press the **ON/OFF** key to save the result and quit service mode. If you do not want to save the result, press **TARE** and confirm the "Abort" message with the **ON/OFF** key.

4.4 Monitoring the test substances

The metrology features of the balance and any possible available adjusting weight must be checked at regular intervals within the scope of quality assurance. For this purpose, the answerable user must define a suitable interval as well as the nature and scope of this check. Information is available on KERN's home page (www.kern-sohn.com) with regard to the monitoring of balance test substances and the test weights required for this. Test weights and balances can be adjusted quickly and at a reasonable price in KERN's accredited DKD calibration laboratory (return to national normal).

4.5 Verification

General:

English

According to the EU guideline 90/384/EEC balances must be verified officially if they are to be used as follows (legally regulated area):

- a) For commercial transactions if the price of goods is determined by weighing
- b) For the production of medicines in pharmacies as well as for analyses in the medical and pharmaceutical laboratory
- c) For official purposes
- d) For the production of finished packages

In case of doubt, please contact your local office of weights and measures.

Verification information: (see chapter 9.3 Declaration of conformity)

An EU qualification approval is available for those balances marked as appropriate for verification in the technical data. In the event that the balance is applied in an area subject to verification as described above, it must be officially verified and re-verified at regular intervals.

Re-verification of a balance is carried out in compliance with the respective legal provisions of the states. The term of verification validity for balances in Germany, for example, is normally 2 years. The legal provisions of the country of use are to be observed.

5 Error messages

Display	Cause and remedy
E11, E16, E18	Internal error (RAM/ROM/EEPROM). Contact dealer.
E48	Error in the scale configuration. Check all parameters in service mode.
ERROR	Software error. Restart the scale with the ON/OFF key. If the error still occurs, replace the storage battery (Chapter 8).
-----	The weight value is unstable or zero setting is not possible. Check the environmental conditions (drafts, vibrations, etc.). If necessary, change the filter settings in the menu (menu block "S4", see Chapter 4). Under certain conditions there could also be a difference of air pressure between the scale housing and the surroundings. Unscrew the rear leveling screws until the ventilation openings under them are free. If water drains out, contact you dealer.
nnnnnn	Overload (load exceeds weighing capacity by more than 9 display steps). Remove the load and set the display to zero with the →0← key. Readjust (calibrate) the scale if necessary.
uuuuuu	When zero was set there was a weight on the scale. When the load is removed this error message appears. Ensure that there is no weight on the pan and then press the →0← key. If the error message occurs again, the scale must be adjusted (calibrated). Note: If the setting "S11" = "Off" was selected in the menu (Chapter 4.2), when zero-setting is done with a weight on the balance and the weight is then removed, the negative weight value is displayed instead of this error message.

6 Cleaning the scale

- **Disconnect the scale from the power supply before starting to clean!**
- Use a soft cloth (no acids, alkalis, or strong solvents).
- Do not use abrasive cleaning agents: they can scratch the display.
- If badly soiled, remove the weighing pan and leveling screws, and clean them separately.
- Observe company-internal and industry-specific regulations regarding cleaning intervals and permitted cleaning agents.

7 Table of geo adjustment values

After a major change of geographical location, the geo adjustment value must be changed according to the following table, and the scale must then be readjusted accordingly (Chapters 4.2 and 4.3).

Latitude north or south in degrees and minutes	Height above sea level in meters											
	0 325	325 650	650 975	975 1300	1300 1625	1625 1950	1950 2275	2275 2600	2600 2925	2925 3250	3250 3575	
	Height above sea level in feet											
	0 1060	1060 2130	2130 3200	3200 4260	4260 5330	5330 6400	6400 7460	7460 8530	8530 9600	9600 10660	10660 11730	
0° 0' - 5° 46'	5	4	4	3	3	2	2	1	1	0	0	
5° 46' - 9° 52'	5	5	4	4	3	3	2	2	1	1	0	
9° 52' - 12° 44'	6	5	5	4	4	3	3	2	2	1	1	
12° 44' - 15° 6'	6	6	5	5	4	4	3	3	2	2	1	
15° 6' - 17° 10'	7	6	6	5	5	4	4	3	3	2	2	
17° 10' - 19° 2'	7	7	6	6	5	5	4	4	3	3	2	
19° 2' - 20° 45'	8	7	7	6	6	5	5	4	4	3	3	
20° 45' - 22° 22'	8	8	7	7	6	6	5	5	4	4	3	
22° 22' - 23° 54'	9	8	8	7	7	6	6	5	5	4	4	
23° 54' - 25° 21'	9	9	8	8	7	7	6	6	5	5	4	
25° 21' - 26° 45'	10	9	9	8	8	7	7	6	6	5	5	
26° 45' - 28° 6'	10	10	9	9	8	8	7	7	6	6	5	
28° 6' - 29° 25'	11	10	10	9	9	8	8	7	7	6	6	
29° 25' - 30° 41'	11	11	10	10	9	9	8	8	7	7	6	
30° 41' - 31° 56'	12	11	11	10	10	9	9	8	8	7	7	
31° 56' - 33° 9'	12	12	11	11	10	10	9	9	8	8	7	
33° 9' - 34° 21'	13	12	12	11	11	10	10	9	9	8	8	
34° 21' - 35° 31'	13	13	12	12	11	11	10	10	9	9	8	
35° 31' - 36° 41'	14	13	13	12	12	11	11	10	10	9	9	
36° 41' - 37° 50'	14	14	13	13	12	12	11	11	10	10	9	
37° 50' - 38° 58'	15	14	14	13	13	12	12	11	11	10	10	
38° 58' - 40° 5'	15	15	14	14	13	13	12	12	11	11	10	
40° 5' - 41° 12'	16	15	15	14	14	13	13	12	12	11	11	
41° 12' - 42° 19'	16	16	15	15	14	14	13	13	12	12	11	
42° 19' - 43° 26'	17	16	16	15	15	14	14	13	13	12	12	
43° 26' - 44° 32'	17	17	16	16	15	15	14	14	13	13	12	
44° 32' - 45° 38'	18	17	17	16	16	15	15	14	14	13	13	
45° 38' - 46° 45'	18	18	17	17	16	16	15	15	14	14	13	
46° 45' - 47° 51'	19	18	18	17	17	16	16	15	15	14	14	
47° 51' - 48° 58'	19	19	18	18	17	17	16	16	15	15	14	
48° 58' - 50° 6'	20	19	19	18	18	17	17	16	16	15	15	
50° 6' - 51° 13'	20	20	19	19	18	18	17	17	16	16	15	
51° 13' - 52° 22'	21	20	20	19	19	18	18	17	17	16	16	
52° 22' - 53° 31'	21	21	20	20	19	19	18	18	17	17	16	
53° 31' - 54° 41'	22	21	21	20	20	19	19	18	18	17	17	
54° 41' - 55° 52'	22	22	21	21	20	20	19	19	18	18	17	
55° 52' - 57° 4'	23	22	22	21	21	20	20	19	19	18	18	
57° 4' - 58° 17'	23	23	22	22	21	21	20	20	19	19	18	
58° 17' - 59° 32'	24	23	23	22	22	21	21	20	20	19	19	
59° 32' - 60° 49'	24	24	23	23	22	22	21	21	20	20	19	
60° 49' - 62° 9'	25	24	24	23	23	22	22	21	21	20	20	
62° 9' - 63° 30'	25	25	24	24	23	23	22	22	21	21	20	
63° 30' - 64° 55'	26	25	25	24	24	23	23	22	22	21	21	
64° 55' - 66° 24'	26	26	25	25	24	24	23	23	22	22	21	
66° 24' - 67° 57'	27	26	26	25	25	24	24	23	23	22	22	
67° 57' - 69° 35'	27	27	26	26	25	25	24	24	23	23	22	
69° 35' - 71° 21'	28	27	27	26	26	25	25	24	24	23	23	
71° 21' - 73° 16'	28	28	27	27	26	26	25	25	24	24	23	
73° 16' - 75° 24'	29	28	28	27	27	26	26	25	25	24	24	
75° 24' - 77° 52'	29	29	28	28	27	27	26	26	25	25	24	
77° 52' - 80° 56'	30	29	29	28	28	27	27	26	26	25	25	
80° 56' - 85° 45'	30	30	29	29	28	28	27	27	26	26	25	
85° 45' - 90° 00'	31	30	30	29	29	28	28	27	27	26	26	

8 Replacing the storage battery

With time, the charging capacity of all lead/acid storage batteries declines. We therefore recommend replacing the storage battery after approximately 300 charging cycles.

Replacing the storage battery does not cause loss of data (menu settings)!

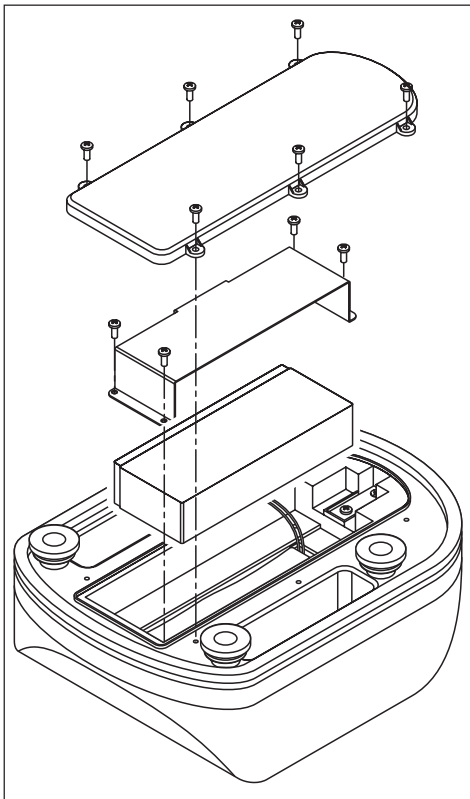

- Remove the weighing pan, turn the scale over, and with the weighing-pan support facing down place the scale on a clean, stable working surface.
- Remove the cover from the storage battery underneath the balance (6 screws).
- Remove the retaining bracket of the storage battery (4 screws).
- Carefully lift the storage battery out of the scale and pull off the two cable clips. **Take care that the two cable clips do not touch each other!**
- Connect the cable clips to the new storage battery: **red cable to plus pole, black cable to minus pole.**
- Insert the new storage battery into the scale and screw the retaining bracket tight.
- Check the condition and correct seating of the rubber seal in the battery cover. Place the battery cover into position and screw it on tightly.
- Connect the AC adapter to the scale and the power supply to charge the new storage battery (Chapter 2.3).
- Dispose of the old storage battery according to the applicable environmental regulations!

9 Specifications and standards

9.1 Technical data

Models	WTB 1,5K0.5IPM	WTB 3K1IPM	WTB 6K2IPM	WTB 15K5IPM
Weighing range (Max)	1.5 kg (3 lb)	3 kg (6 lb)	6 kg (15 lb)	15 kg (30 lb)
Readout (d)	0,5 g (0,001 lb)	1 g (0,002 lb)	2 g (0,005 lb)	5 g (0,01 lb)
Verific. value	1,5 g	1 g	2 g	5 g
Min. load (Min)	10 g	20 g	40 g	100 g
Weighing pan	Stainless steel			
Housing	ABS light gray IP65			
Displays	6-digit LED displays on front and rear of scale, variable brightness, character height 25 mm/1 in., 9 integrated status LEDs			
Keypad	4 keys with action point			
Leveling	With level indicator (built into the front of the housing) and 4 leveling screws			
Power supply	Lead/acid storage battery, 6V/5Ah, chargeable in balance using AC adapter supplied with scale (scale operates from mains while charging), charging time 15 h, mains-free operation up to 50 h			
Operating conditions	-10 °C ... +40 °C, 10 % ... 95 % rel. humidity, non-condensing			
Storage conditions	-25 °C ... +50 °C, 10 % ... 95 % rel. humidity, non-condensing			
Weighing units	g, kg, lb			
Weight of scale	4.4 kg (incl. storage battery and weighing pan)			

Models	WTB 1,5K0.5IP	WTB 3K1IP	WTB 6K2IP	WTB 15K5IP
Weighing range	1.5 kg (3 lb)	3 kg (6 lb)	6 kg (15 lb)	15 kg (30 lb)
Readout	0,5 g (0,001 lb)	1 g (0,002 lb)	2 g (0,005 lb)	5 g (0,01 lb)
Weighing pan	Stainless steel			
Housing	ABS light gray IP65			
Displays	6-digit LED displays on front and rear of scale, variable brightness, character height 25 mm/1 in., 9 integrated status LEDs			
Keypad	4 keys with action point			
Leveling	With level indicator (built into the front of the housing) and 4 leveling screws			
Power supply	Lead/acid storage battery, 6V/5Ah, chargeable in balance using AC adapter supplied with scale (scale operates from mains while charging), charging time 15 h, mains-free operation up to 50 h			
Operating conditions	-10 °C ... +40 °C, 10 % ... 95 % rel. humidity, non-condensing			
Storage conditions	-25 °C ... +50 °C, 10 % ... 95 % rel. humidity, non-condensing			
Weighing units	g, kg, lb			
Weight of scale	4.4 kg (incl. storage battery and weighing pan)			

9.2 Dimensions

All dimensions in millimeters. Height measured with leveling screws completely screwed in.

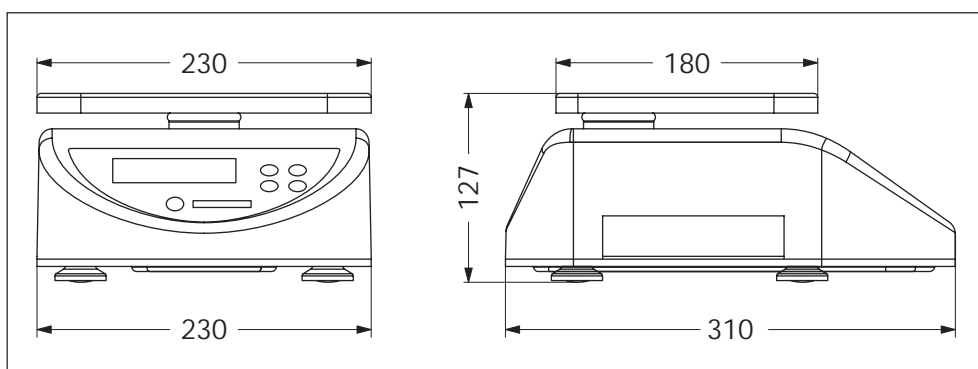

9.3 Declaration of conformity

Konformitätserklärung

Declaration of conformity for apparatus with CE mark
Konformitätserklärung für Geräte mit CE-Zeichen
Déclaration de conformité pour appareils portant la marque CE
Declaración de conformidad para aparatos con marca CE
Dichiarazione di conformità per apparecchi contrassegnati con la marcatura CE

English	We hereby declare that the product to which this declaration refers conforms with the following standards.
Deutsch	Wir erklären hiermit, dass das Produkt, auf das sich diese Erklärung bezieht, mit den nachstehenden Normen übereinstimmt.
Français	Nous déclarons avec cela responsabilité que le produit, auquel se rapporte la présente déclaration, est conforme aux normes citées ci-apres.
Español	Manifestamos en la presente que el producto al que se refiere esta declaración esta á de acuerdo con las normas siguientes.
Italiano	Dichiariamo con ciò che il prodotto al quale la presente dichiarazione si riferisce è conforme alle norme di seguito citate.

English

Electronic Scale: KERN WTB

Mark applied	EU Directive	Standards	Approval Testcertificate N°
CE	73/23EEC Low Voltage	EN 61010-01	
CE	89/336/EEC EMC	EN 61326-1:1997+A1 :98 (CLASS B) EN 61326-1:1997+A1 :98 (Minmal Requirements)	
CE [year] [code] M1)	90/384EEC Non automatic weighing Instruments 1)	EN 45501 1)	T 6682 1)

1) applies only to certified balances
gilt nur für geeichte Waagen
valable uniquement pour les balances vérifiées
sólo aplicable a balanzas verificadas
la dichiarazione vale solo per le bilance omologate

Date: 01.03.05**Signature:**

Gottl. KERN & Sohn GMBH
Management

Notice

Certified balances and balances used for legal applications have the EU type approval. The year of the initial verification is shown next to the CE mark. Such balances are verified in the factory and carry the „M“ mark on the actual balance and the packaging. The year of initial verification is shown next to the CE mark. The GEO value of verified balances explains for which location of use the balance has been verified. This GEO value is shown on the balance itself and on the packing. Further details see GEO value table (see chapter 7).

Hinweise

Für geeichte/eichpflichtige Waagen liegt eine EU Bauartzulassung vor. Das Jahr der ersten Eichung ist neben dem CE Zeichen aufgeführt. Solche Waagen sind ab Werk geeicht und tragen die Kennzeichnung „M“ auf dem Gerät selbst und auf der Verpackung. Der GEO-Wert gibt bei vom Hersteller geeichten Waagen an, für welchen Aufstellungsort die Waage geeicht ist. Dieser GEO-Wert befindet sich auf der Waage sowie der Verpackung. Genaueres ist der GEO-Wert-Tabelle (siehe Kap. 7) zu entnehmen.

Remarques

Les balances vérifiées/admissibles à la vérification font l'objet d'une approbation de modèle UE. L'année de la vérification primitive est indiquée à côté de la marque CE. Ces balances sont vérifiées d'origine et portent la marque „M“ sur l'appareil lui-même et sur l'emballage. Le valeur GEO indique le lieu d'utilisation pour lequel la balance été vérifiée. Ce valeur GEO se trouve sur la balance ainsi que sur l'emballage. Veuillez trouver plus de détails dans le tableau GEO (voir chap. 7).

English

Notas

Las balanzas verificadas/verificables cuentan con una aprobación de modelo UE. El año de la primera verificación está indicado al lado del distintivo CE. Estas balanzas están verificadas en fábrica y llevan la designación „M“ sobre el propio aparato y sobre el embalaje. El valor GEO indica el lugar de ubicación por lo cual la balanza está verificado. El valor se encuentra sobre la balanza así como sobre el embalaje. Por favor toman demás detalles de la tabla GEO (ver cap. 7).

Avvertenza

Per le bilance approvate esiste un'approvazione CE del tipo. L'anno della prima verifica è indicato a fianco della marcatura CE. I tipi marcati con un contrassegno „M“ su sfondo verde peino possono essere impiegati da subito. Il coefficiente GEO di bilance omologate indica per quale luogo la bilancia è stata omologata. Questo coefficiente GEO si trova sulla bilancia e sull'imballo. Ulteriori informazioni vedi tabella coefficiente GEO (vedi cap. 7).