

Ohaus VF Series Floor and Pit Mount Platforms



*Painted steel 1250 x 1500 mm model
platform with CD-11 indicator*



*Stainless steel 800 x 800 mm model
platform with CW-11 indicator*

Dependability, German-engineered Quality, Ohaus Brand Value.

The Ohaus VF Floor and Pit Mount Series is a cost-competitive lineup of painted mild steel and stainless steel floor and pit mount platforms that do not compromise on quality. Its high-quality German-engineered structure with stainless steel IP68 hermetically sealed load cells ensure durability and reliability that will withstand years of daily usage in industrial environments. Platform models combined with Ohaus indicators and with 2nd stage approvability provide consistent and accurate weighing results. With available ramps, pit frames and mounting accessories, the Ohaus VF Floor and Pit Mount Series offers a unique combination of affordability, versatility and quality that your company can depend on for years and years.

Standard Features Include:

- Four popular capacities: 300kg, 600kg, 1,500kg and 3,000kg, in 5 sizes: from 800 x 800 mm to 1,500 x 2,000 mm
- Painted mild steel or bead blasted stainless steel fixed deck models, with structural channel bracing that ensures a rigid and durable construction
- Combination floor-pit mount design provides versatility for portable or stationary placement, above or below ground installation
- Four IP68 electro-polished stainless steel load cells, laser-weld hermetically sealed (OIML) – standardized on all models
- Four load cell mounted, swivel-design, self-adjusting stainless steel feet with removable rubber caps
- Top access IP67 dust and water immersion protected stainless steel junction box with heavy duty 5m long cable
- Available 2nd stage verified scale models 1:3000e with Ohaus CD-11 or CW-11 indicators (non-approved displayed resolution up to 1:15000d)
- Ohaus indicators featuring backlit LCD displays with high-visibility 25mm high digits, 4 weighing units (kg, g, lb, oz), 6 “C” alkaline battery operation, display hold (CD-11) and dynamic weighing (CW-11) functions
- Available pit frames, mounting plates, and ramps with bottom support channels that resist bending during heavy loads

VF Series

Floor and Pit Mount Platforms

VF Series Floor and Pit Mount Platforms

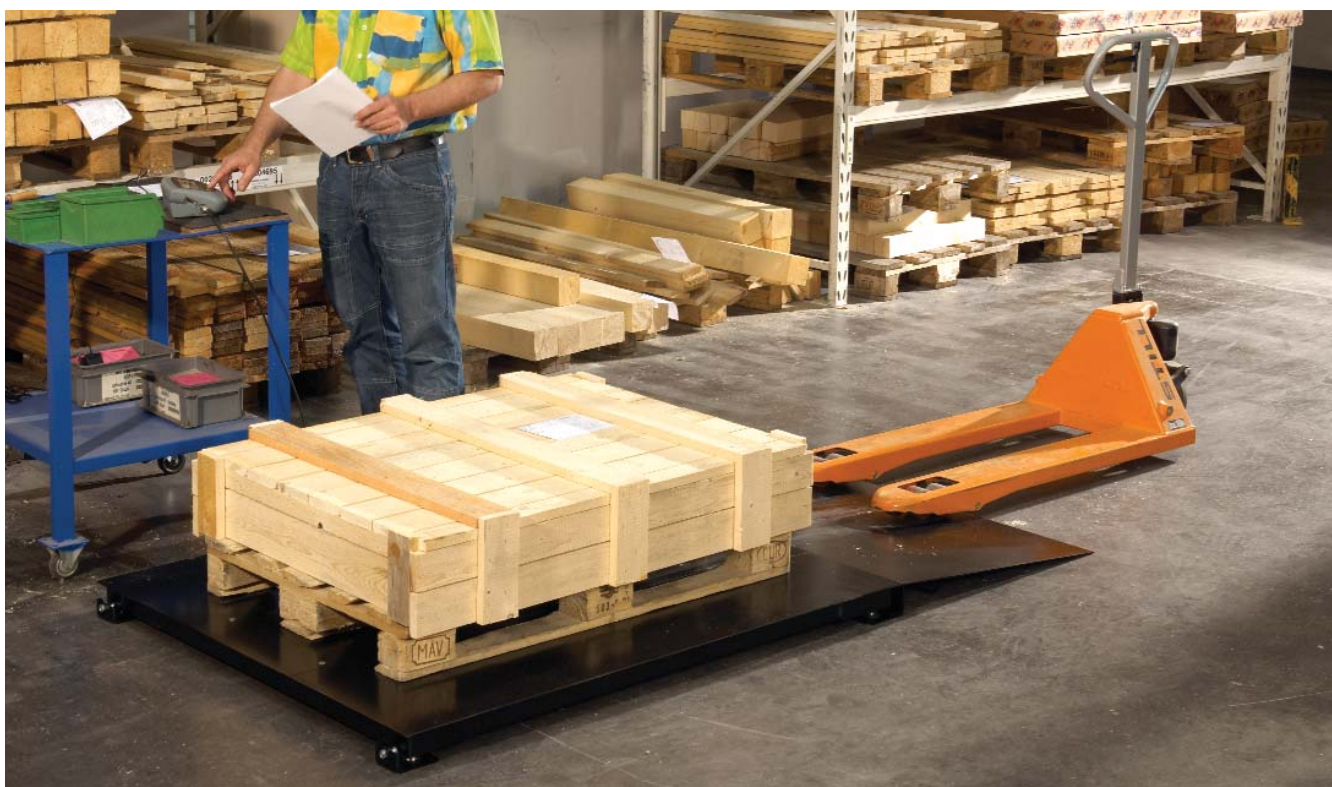

Included Components and Features



Eye Bolts (2) and Mounting Dowels (4):

- Threaded eye bolts are included for ease of lifting and installation
- Eye bolts are made of galvanized mild steel
- Floor mounting dowels are made of mild steel or stainless steel



Load Cell Mounted Stainless Steel Feet (4):

- Pendulum design ensures even footing to the ground
- Includes removable rubber cap to minimize slippage
- Feet are height adjustable and can be locked into position to ensure consistent leveling



Junction Box:

- Easy access from the top of the platform
- Stainless steel (AISI304) IP67 dust and water immersion protection for the potentiometers and summing board housed in the enclosure
- Enclosure Size: 193L x 75W x 45H mm, Cable Length: 5m



Multi-Purpose Cleaner:

- Included with stainless steel models
- Multi-purpose rust protectant / cleaning oil safe for food industry

Available Accessories

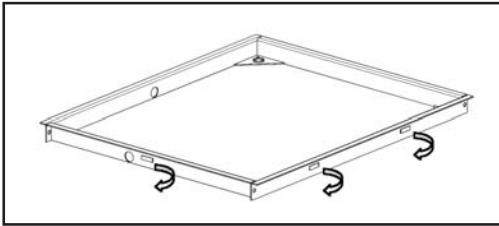

PIT FRAMES:

Platform Size (mm)	Actual Dimensions (mm)	Mild Steel Part Number	Stainless Steel Part Number
800 x 800	890 x 890 x 90H	22015392	22015493
1,000 x 1,000	1,090 x 1,090 x 90H	22015393	22015494
1,250 x 1,500	1,340 x 1,590 x 90H	22015394	22015495
1,500 x 1,500	1,590 x 1,590 x 90H	22015396	22015496
1,500 x 2,000	1,590 x 2,090 x 90H	22015397	22015497

- For VFP Models: Black painted mild steel
- For VFS Models: Stainless steel (AISI 304)

Features:

- Multiple fixing brackets that help anchor the frame to the wall
- Tapered foot mounting guides for easy installation of floor-pit mount platforms

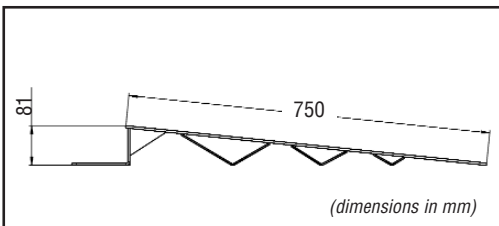
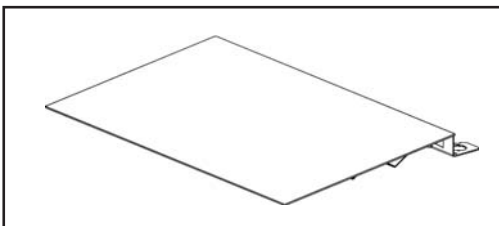

RAMPS:

Width (mm)	Mild Steel Part Number	Stainless Steel Part Number
800	22015464	22015473
1,000	22015465	22015474
1,250	22015466	22015475
1,500	22015467	22015476

- For VFP Models: Black painted mild steel
- For VFS Models: Stainless steel (AISI 304)

Features:

- VF Series ramps are made of 5mm thick metal (mild steel or stainless steel) with bottom support channels that resist bending during heavy loads

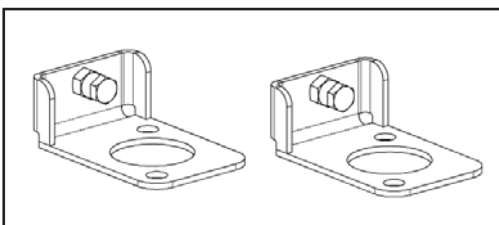

1 Set: (2) FOOT PLATES (including 4 mounting bolts):

Item Description	Part Number
Mild Steel	22015499
Stainless Steel	22015581

VF Series Floor and Pit Mount Platforms

Platform Dimensions (A x B):	Platform Models			
800 x 800 mm (CS)	VFP/VFS-CS300	VFP/VFS-CS600		
1,000 x 1,000 mm (DS)	VFP/VFS-DS300	VFP/VFS-DS600		
1,250 x 1,500 mm (E)		VFP/VFS-E600	VFP/VFS-E1500 ^{a/}	VFP/VFS-E3000 ^{a/}
1,500 x 1,500 mm (ES)		VFP/VFS-ES600	VFP/VFS-ES1500 ^{a/}	VFP/VFS-ES3000 ^{a/}
1,500 x 2,000 mm (G)			VFP/VFS-G1500 ^{b/}	VFP/VFS-G3000 ^{b/}
Material: VFP Models	Mild steel, black painted, non-treaded surface, fixed top plate 5 mil thick			
Material: VFS Models	Stainless steel (AISI 304), bead blasted, non-treaded surface, fixed top plate 5 mil thick			
Platform Capacity	300kg	600kg	1500kg	3000kg
Maximum Safe Static Load:				
with Central Load	1,000 kg	3,000 kg	a/4,500 kg	b/3,300 kg
with Side Load	800 kg	2,000 kg	a/3,000 kg	b/2,200 kg
with Corner Load	400 kg	1,000 kg	a/1,500 kg	b/1,000 kg
Feet	4 x swivel design, stainless steel with rubber caps, adjustable height			
Load Cell Model	4 x Ohaus SBH, double-bending beam, OIML approved			
Load Cell Capacity Emax	250 kg	500 kg	1,000 kg	2,000 kg
Load Cell Safe Overload Limit	150% of Emax			
Load Cell Material	Stainless steel, electro-polished			
Load Cell Protection	IP68, laser-weld hermetically sealed			
Load Cell Output Impedance	350 Ohm ± 1 Ohm			
Load Cell Excitation Voltage	5V ~ 15V, DC/AC			
Load Cell Cable Length	3.1 m			
Load Cell EC Type Approval	TC6114			
Junction Box	IP67, Stainless steel (AISI 304), with heavy duty 5m long cable			
Accessories	Ramps, Mounting Foot Plates, Pit Frames			
Scale Model, 1st Stage approved	Add "11" at end of platform model name: ex. VFP-CS30011			
Scale Model, 2nd Stage Verified, 3000e	Add "11M" at end of platform model name: ex. VFP-CS30011M			
Indicator	Ohaus CD-11		Ohaus CW-11	
Material and Protection	ABS plastic		Stainless steel (304), IP65	
Weighing Units	kg, g, lb, oz			
Display	Backlit LCD, 25 mm high, 6-digit, 7-segment			
Interface	Built-in RS232			
Power	AC adapter or 6 "C" cell		AC hardwired or 6 "C" cell	
Other Functions	Display Hold		Dynamic weighing	

Outline Dimensions

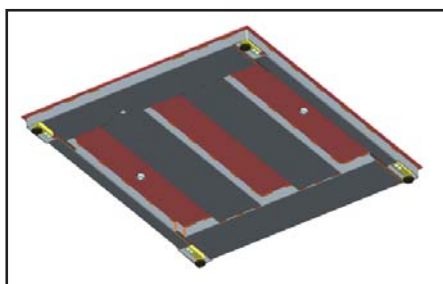
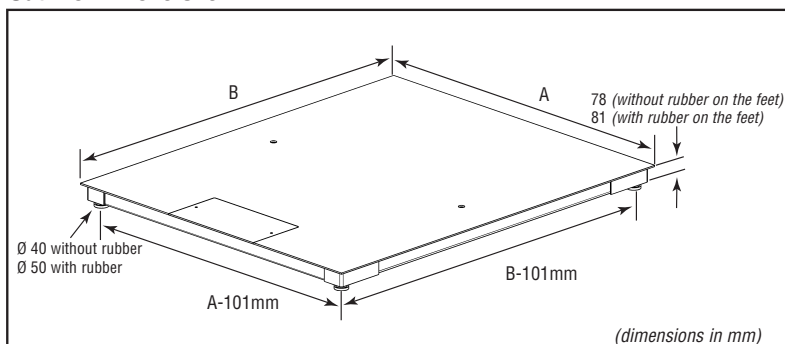

- VF Series bottom view:
- Steel channel design for structural toughness
 - 4 x load cell mounted stainless steel swivel feet
 - 4 x stainless steel IP68 load cells in all models

Your Local Ohaus Dealer:



ISO 9001:2000
Registered Quality Management System

www.ohaus.com

P/N 80774256 © Copyright Ohaus Corporation

